

FIRE RESISTANCE CLASSIFICATION REPORT No. 15285C

Owner of the classification report:

AGC Glass Europe
166, Chaussée de la Hulpe
1170 Brussels
Belgium

Introduction:

This classification report defines the classification assigned to an unloaded glazed wall, type: Pyrobelite 10_Timber frame_silicone, in accordance with the procedures given in EN 13501-2: 2007+A1:2009: Fire classification of products and building elements – Part 2: Classification using data from fire resistance tests, excluding ventilation services.

This classification report consists of eleven pages and seven annexes and may only be used or reproduced in its entirety.

1 Details of classified product

1.1 General

The specimen is defined as an unloaded glazed wall – type: Pyrobelite 10_Timber frame_silicone. It is evaluated in respect of the fire performance characteristics given in clause 5 of EN 13501-2: 2007+A1:2009.

1.2 Description

The element is fully described in the test report provided in support of this classification listed in clause 2.1. The drawings of this test report are enclosed in the annexes 1 till 5 of this classification report.

Composition of the test specimen:

The unloaded glazed wall consists of glass panes in a timber frame.

1.2.1 Glazing system:

The glazing system consists of glass panes [1]-[6], setting blocks [7], clip-on beads [8], bead fixings [9], glazing strips [10] and sealants [11]. The exact composition of the glass panes is confidential and is communicated to the laboratory.

[1]-[6] Glass panes – type: Pyrobelite 10 – nominal glass thickness: 11.0 mm ± 1.0 mm – measured glass thickness: 10 mm.

- position: shown in annex 1 of this report.
- fixation: clasped between the glazing beads.
- orientation: the glass panes are asymmetrical: the glass layer of 6 mm thickness at the exposed side.

	Dimensions of the glass panes: (width x height)	Dimensions of the exposed area: (width x height)	Reference:
[1]	877 mm x 956 mm	833mm x 812 mm	CM21965-03-501
[2]	750 mm x 956 mm	706 mm x 812 mm	CM21965-04-502
[3]	877 mm x 956 mm	833 mm x 812 mm	CM21965-03-502
[4]	750 mm x 956 mm	706 mm x 812 mm	CM21965-04-501
[5]	1683 mm x 850 mm	1639 mm x 806 mm	CM21965-02-501
[6]	1100 mm x 2874 mm	1056 mm x 2830 mm	CM21965-01-501

- [7] Setting block – material: hardwood – type: Beech – dimensions: 80 mm x 20 mm x 5 mm – density: 655 kg/m³ (MV).
- number: two per glass pane.
 - position: under the glass panes.
- [8] Glazing bead – material: hardwood – type: Meranti – dimensions: 25 mm x 27 mm – density: 460 kg/m³ (MV).
- position: at the exposed and unexposed side.
 - fixation:
 - with screws [9] – material: steel – diameter: 4.5 mm – length: 50 mm;
 - centre/centre distance: 200 to 230 mm.
- [10] Glazing strip – material: self-adhesive ceramic paper – type: Superwool X607 – dimensions: 20 mm x 5 mm – density: 210 kg/m³ (NV).
- position: between the glazing beads and the glass panes.
- [11] Sealant – material: neutral silicone – trade and type: Dow Corning Firestop 700.
- position: sealing between the glass panes and the glazing beads.

1.2.2 Framing system:

The symmetrical framing system includes the frame components [12]-[14] and the fixing pieces [15]-[17]. The timber frame is composed of two units screwed to one another.

- [12] Transoms and mullions – material: Meranti – section dimensions: 33 mm x 71 mm – density: 550 kg/m³ (NV).
- fixation to the surrounding building structure:
 - with anchors [15] – material: steel – brand and type: Hilti 100 HT – diameter: 10 mm – length: 112 mm;
 - centre/centre distance: 450 mm.
 - fixation of the units:
 - with screws [16] – material: steel – diameter: 5 mm – length: 60 mm;
 - centre/centre distance: 500 mm.
- [13] Intermediate transoms and intermediate mullions – material: Meranti – section dimensions: 46 mm x 71 mm – density: 550 kg/m³ (NV).
- fixation: glued to the connecting (intermediate) transom or (intermediate) mullion.

- [14] Cover lath – material: Meranti – outer dimensions: 12 mm x 46 mm – density: 550 kg/m³ (NV).
- position: over the joint between the two units.
 - fixation:
 - with screws [17] – material: steel – diameter: 3.5 mm – length: 35 mm;
 - centre/centre distance: 300 mm (alternating from edge).
- [18] Setting block – material: calcium silicate – type Promatect-H – dimensions: 100 mm x 50 mm x 15 mm – density: 960 kg/m³ (NV).
- position: between the timber frame and the floor connection of the surrounding building structure .
 - centre/centre distance: 650 to 700 mm.
- [19] Mineral wool – type: Thermal insulation Superwool X607 – initial density: 96 kg/m³ – compressed to a thickness of 25 mm.
- position: between the timber frame and the surrounding building structure.

2 Test reports/extended application reports and test results in support of the classification

2.1 Test reports/Extended application reports

Name of the laboratory that carried out the test	Identification number of the reports	Owner of the report	Date of the test	Test method/ Field of extended application rules
WFRGENT nv	15285A	AGC Glass Europe	23/12/2011	EN 1363-1:1999 EN 1364-1:1999
WFRGENT nv	15285B	AGC Glass Europe	23/12/2011	EN 15254-4:2008+A1:2011

Exposure conditions during the fire resistance test:

Temperature/time curve: standard as in EN 1364-1:1999.

Direction of exposure:

- the glazing system is asymmetrical: the layer of 6 mm thickness at the exposed side.
- the framing system is symmetrical.

One vertical edge is free, the other edges are fixed.

2.2 Test results

Parameter	Results
Loadbearing capacity	Not applicable
Integrity	
Time of ignition of a cotton pad	No failure at test termination
Time of occurrence of sustained flaming	After 36 minutes
Time of failure of gap gauge criterion	No failure at test termination
Thermal insulation	
Time after which the mean temperature at the unexposed side exceeds 140 °C	After 13 minutes
Time after which the maximum temperature rise at the unexposed side exceeds 180 °C	After 13 minutes
Radiation	
Time after which the radiation intensity exceeds 15 kW/m ²	No failure at test Termination
Mechanical action	Not applicable

The test duration was 36 minutes.

3 Classification and field of application

3.1 Reference of classification

This classification has been carried out in accordance with clause 7.5.2 of EN 13501-2:2007+A1:2009.

3.2 Classification

The element is classified according to the following combinations of performance parameters and classes as appropriate. No other classifications are permitted.

The classifications are only valid for the direction of exposure as described in clause 2.1.

EW 30, EW 20
E 30, E 20

3.3 Field of direct application

This classification is valid for the following end use applications according to EN 1364-1:1999.

The results of the fire test are directly applicable to similar constructions where one or more of the changes listed below are made and the construction continues to comply with the appropriate design code for its stiffness and stability:

- a) Unlimited decrease in the partition width.
- b) Unlimited increase in partition width*.
- c) Unlimited decrease in partition height. Extension in height above 3 m is only allowed according to the extended field of application.
- d) Decrease in linear dimensions of panes.
- e) Change in the aspect ratio of the panes provided that the largest dimension of the pane and its area are not increased.
- f) Decrease in distance between mullions and/or transoms.
- g) Decrease in distance between fixing centres.
- h) Increase of dimensions of framing members.
- i) Allowances for expansion if none were incorporated in the test specimen.
- j) Change in angle of installation up to 10° from the vertical.

* the radiation intensity for an increased width till $+\infty$ meters remains below 15 kW/m^2 after 30 minutes. The calculated values are shown in test report 15285A – Annex 10.

3.4 Field of extended application

This classification is valid for the following end use applications according to EN 15254-4: 2008+A1:2011.

The results of the fire test are directly applicable to similar constructions where one or more of the changes listed below are made. Other changes are not permitted.

The justification and the calculations are given in the extended application report no.15285B.

3.4.1 Exchange of the fire resistant glass

The “Pyrobelite 10” glass panes can be replaced by thicker symmetrical “Pyrobel xx” glass panes, considering the rules listed in extended application report no. 15285B.

(xx: nominal thickness of the pane)

3.4.2 Asymmetrical fire resistant glass

The asymmetrical fire resistant glass can only be used with the glass layer of 6 mm thickness at the exposed side.

3.4.3 Individual rectangular glass panes: aspect ratio and increase in area

The maximum dimensions of the rectangular, triangular and four sided shaped glass panes are represented by the thickest lines in annex 6, for the indicated E classifications.

The maximum dimensions of the other non rectangular glass panes are represented by the thinnest lines in annex 6, for the indicated E classifications.

3.4.4 Individual panes in a wall: radiation

The maximum dimensions of the rectangular, triangular and four sided shaped glass panes are represented by the thickest lines in annex 6, for the indicated EW classifications.

The maximum dimensions of the other non rectangular glass panes are represented by the thinnest lines in annex 6, for the indicated EW classifications.

3.4.5 Exchange of timber glazing beads

- In all cases, the exchange of timber species should be on the basis of density and/or comparative char rate tests (when available), calculations according to EN 1395-1-2 or reference values. These shall demonstrate that the fire performance of the replacement timber bead is either the same or better than that used in the reference test.
- For EI classification of fire resistant glazed elements, exchange of the bead profile from a sloped or chamfered bead to a flat bead of the same height is allowed.
- The bead depth may be increased without restraint: the bead depth must be at least 25 mm.

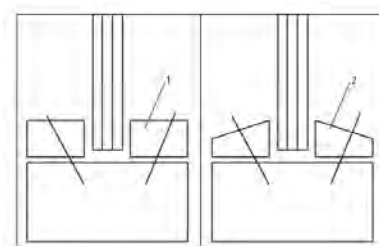

Principal drawing 1

3.4.6 Bead surface coverings

Decorative surface coverings of the glazing beads may be added provided it can be demonstrated that the covering material achieves at least Class A2 when tested according to EN 13501-1. In addition it must be shown that they do not adversely affect the fire performance of the fire resistant glazed element, e.g. in the case of replacement of coverings that provide a contribution to insulation performance.

3.4.7 Asymmetrical framing systems

The framing system is completely symmetrical and can be used in both directions.

3.4.8 Exchange of frames

Frames can be manufactured using some or all of the tested junction types:

- Type A: four panes joining together;
- Type B: three panes joining together at one point including a full height vertical pane;
- Type C: three panes joining together at one point including a full width horizontal pane;
- Type D: two full panes side by side (horizontal and vertical) is not allowed;
- Type E: corner junction.

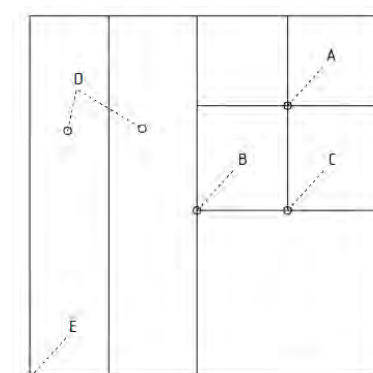

Principal drawing 2

3.4.9 Timber frames

Exchange of the type of timber species used for the frame is allowed for fire resistant glass from the same glass product group as follows:

- timber with the same or higher density and/or moisture content, with the same or lower char rate and identical profile: the density must have at least a nominal value of 550 kg/m³;
- increased thickness of the frame: the thickness of the frame must be at least 71 mm.

3.4.10 Frame surface coverings

Decorative surface coverings of the framing members may be added provided it can be demonstrated that the covering materials achieves at least Class A2 when classified according to EN 15501-1. In addition it must be shown that they do not adversely affect the fire performance of the fire resistant glazed element, e.g. in the case of replacement of coverings that provide a contribution to the insulation performance.

3.4.11 Increase in overall dimensions and area of the partition

The maximum dimensions of the fire resistant glazed partition are represented by the thickest lines in annex 7, for the indicated E classifications.

3.4.12 Increase in dimensions for fire glazed partitions: radiation

The maximum dimensions of the fire resistant glazed partition are represented by the thickest lines in annex 7, for the indicated EW classifications.

3.4.13 Replication of the fire resistant glazed partition with reference to radiation

A wider construction achieved by replicating the fire resistant glazed partition as tested, by adding more units of the same fire resistant glazed partition side by side is allowed for all the classifications listed in §3.2 of this classification report.

3.4.14 Changing in installation angle

A change in the angle of installation of up to +/- 10 degrees from the vertical is allowed. No further increase in the installation angle is allowed.

4 Duration of the validity of the classification report

At the time the standard EN 13501-2:2007+A1:2009 was published, no decision was made concerning the duration of validity of the classification document.

5 Limitations

This classification document does not represent type approval nor certification of the product.

SIGNED

APPROVED

This document is the original version of this classification report and is written in English.

This report may be used only literally and completely for publications. - For publications of certain texts, in which this report is mentioned, our permission must be obtained in advance.

The authenticity of the electronic signatures is assured by Belgium Root CA.

Front view (unexposed side) – dimensions.

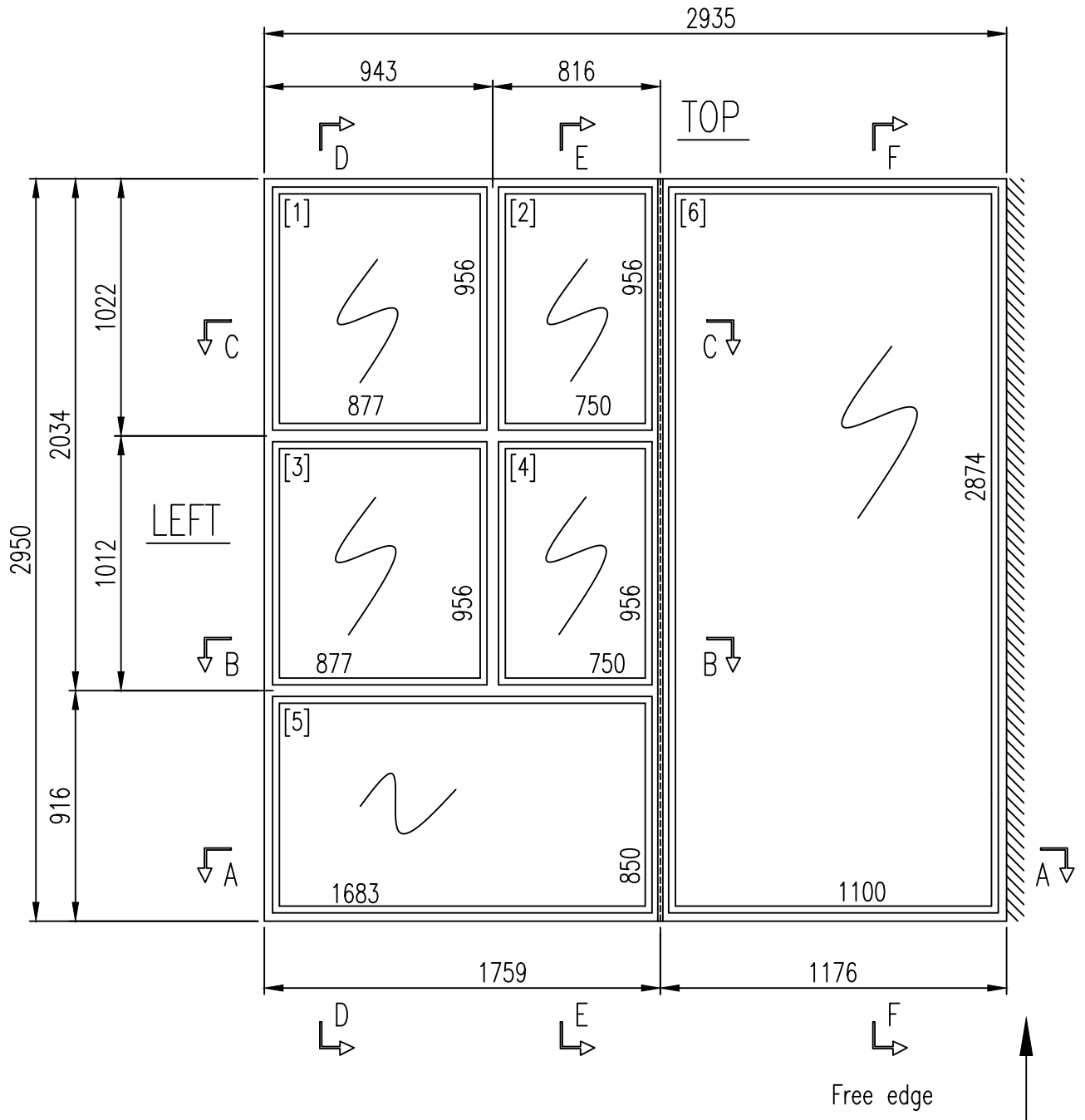

Section AA.

EXPOSED SIDE

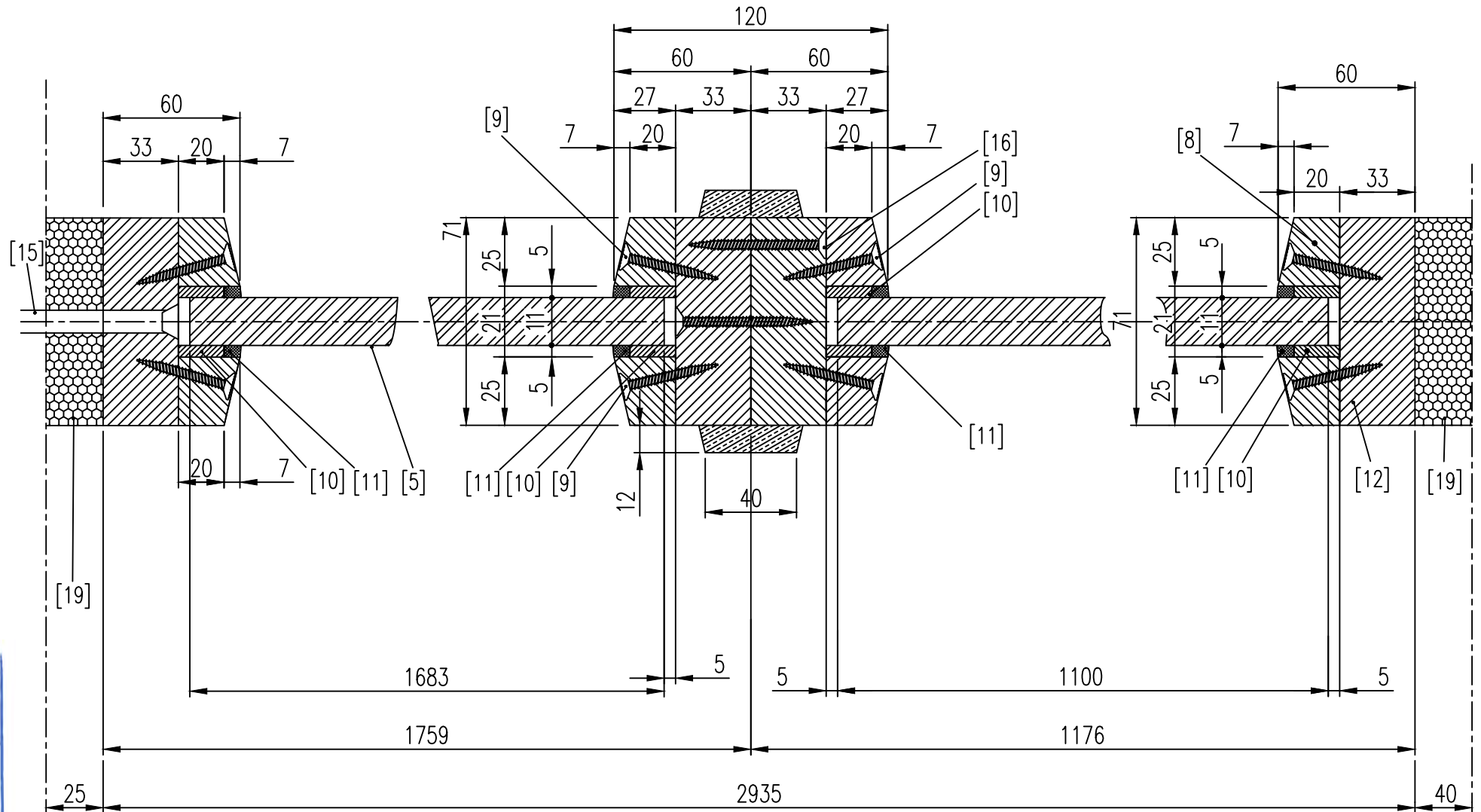

Sections BB and CC.

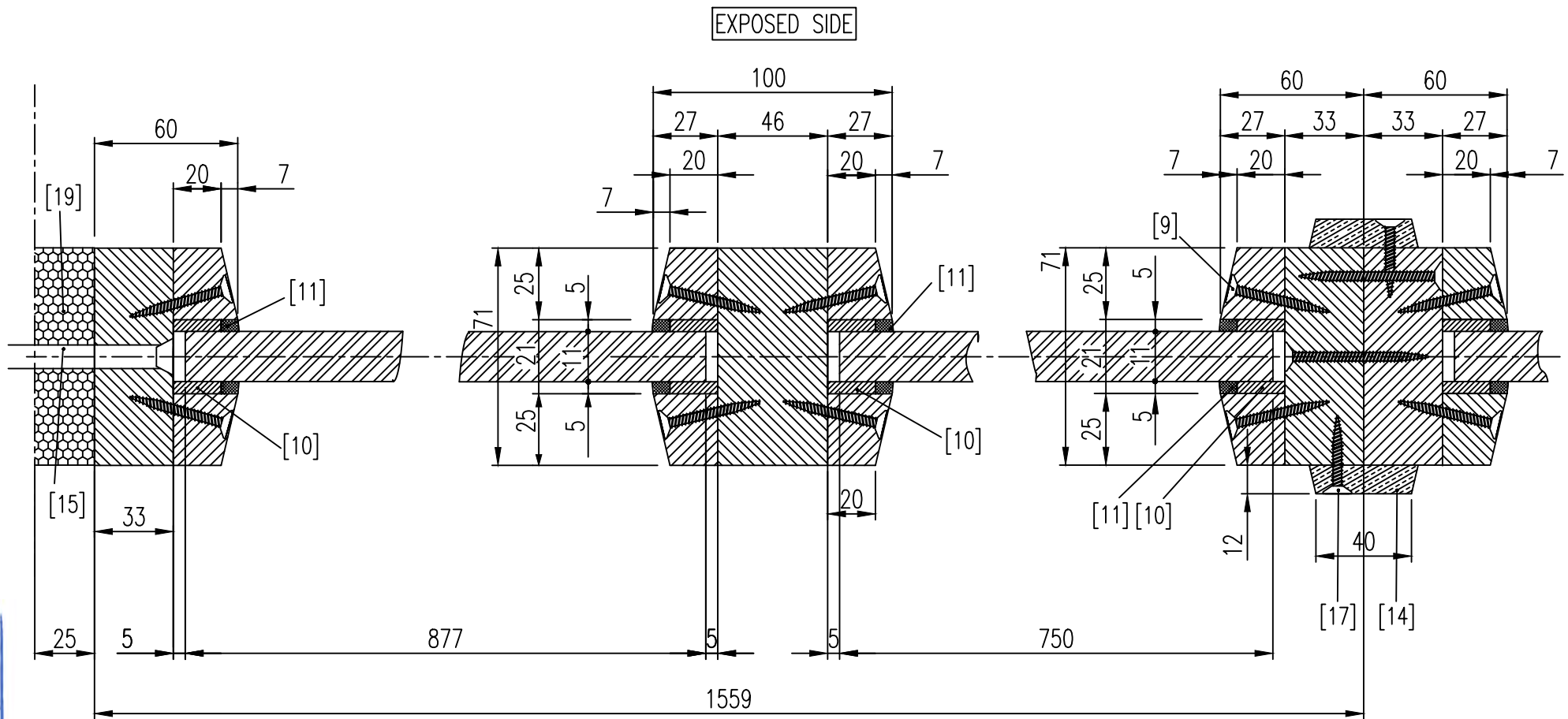

Section FF.

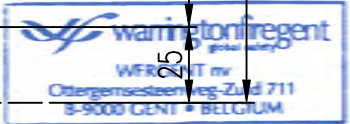
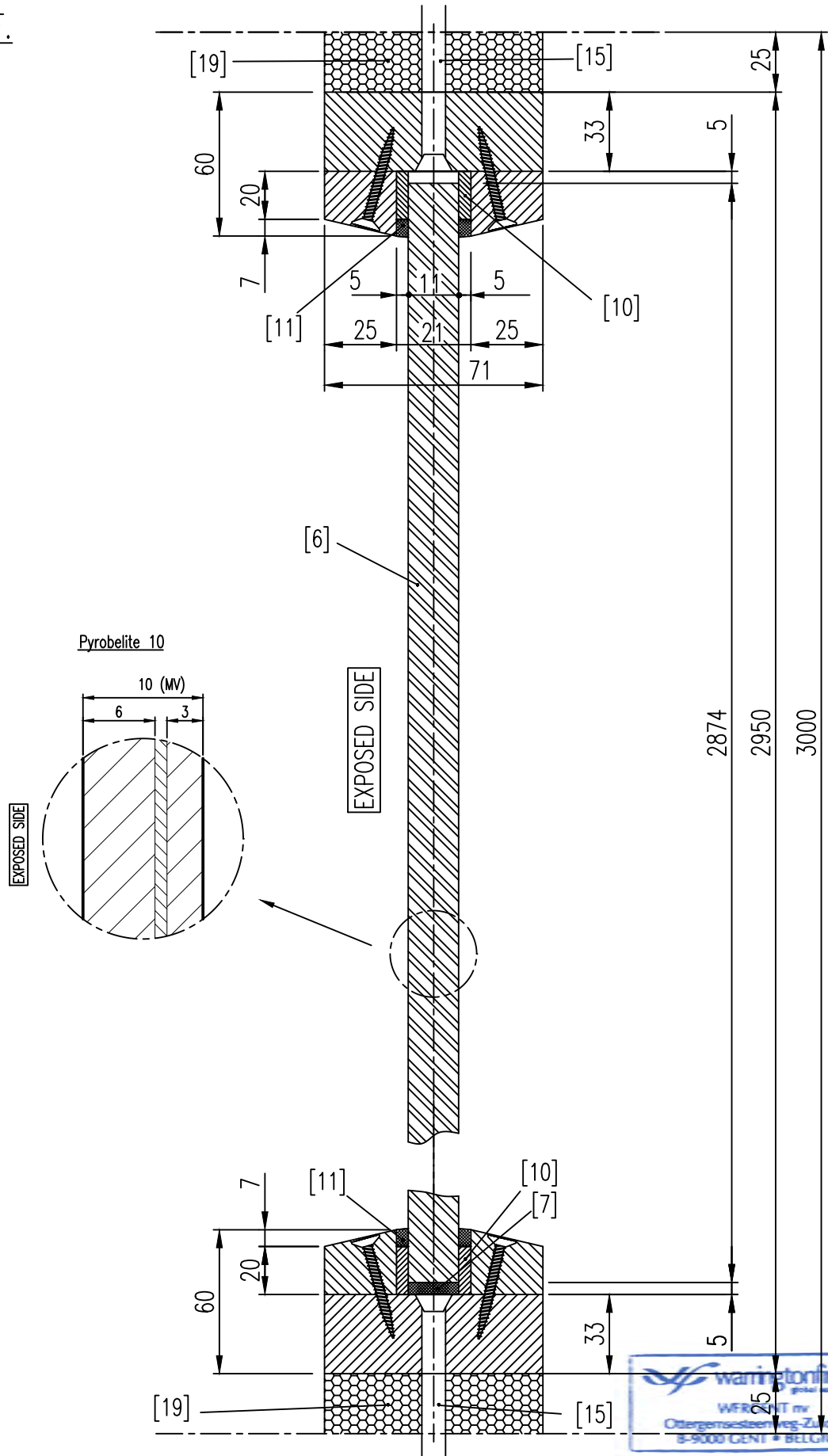

Individual rectangular glass panes: aspect ratio and increase in area

The extended dimensions are only valid for the following classifications:

- E 30, E 20;
- EW 30, EW 20.

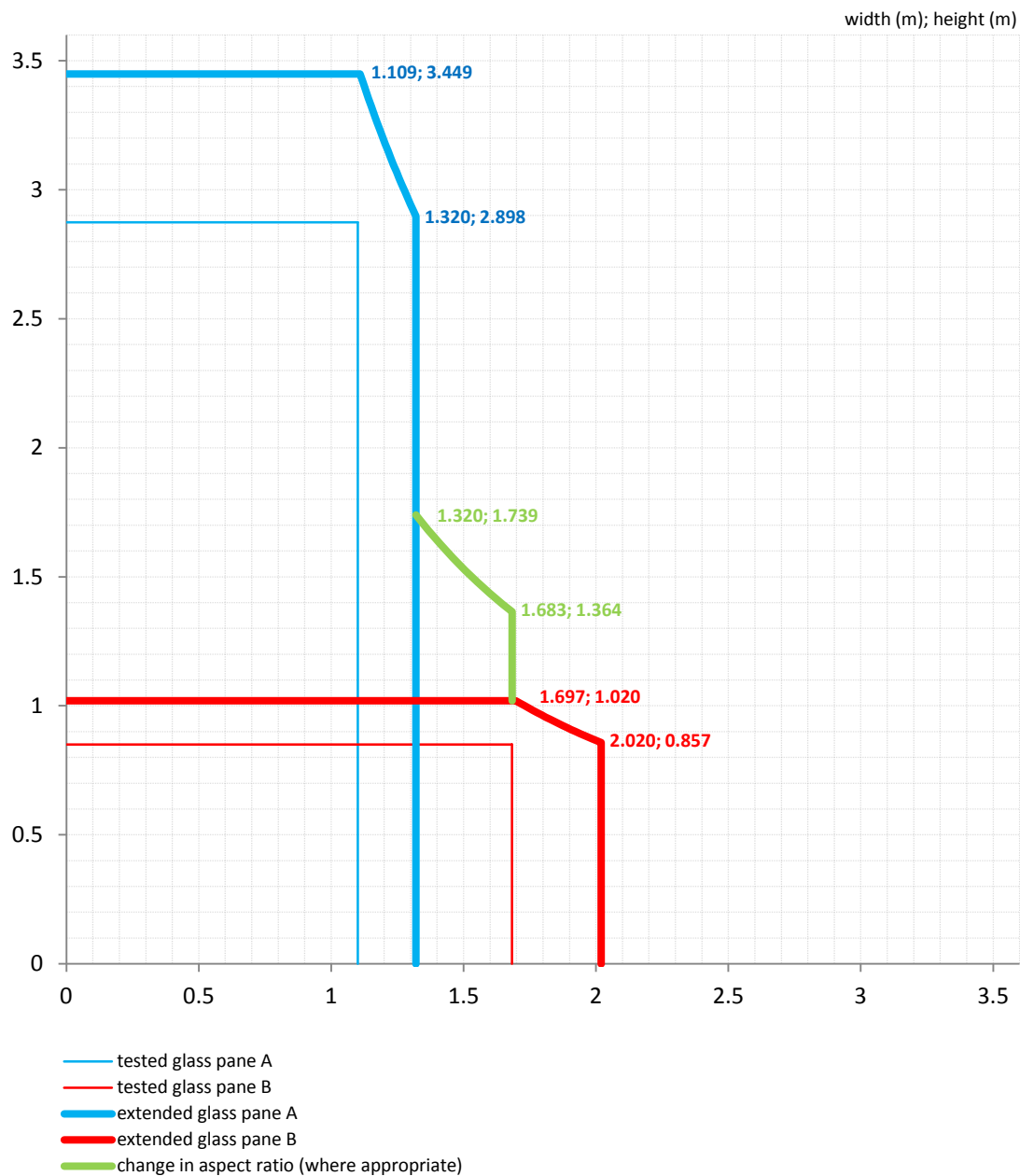

Note:

The maximum dimensions of the rectangular, triangular and four sided shaped glass panes are represented by the thickest lines (extended dimensions). The maximum dimensions of the other non rectangular glass panes are represented by the thinnest lines (tested dimensions).

Increase in overall dimensions and area of the partition as a whole

The extended dimensions are only valid for the following classifications:

- E 30, E 20;
- EW 30, EW 20.

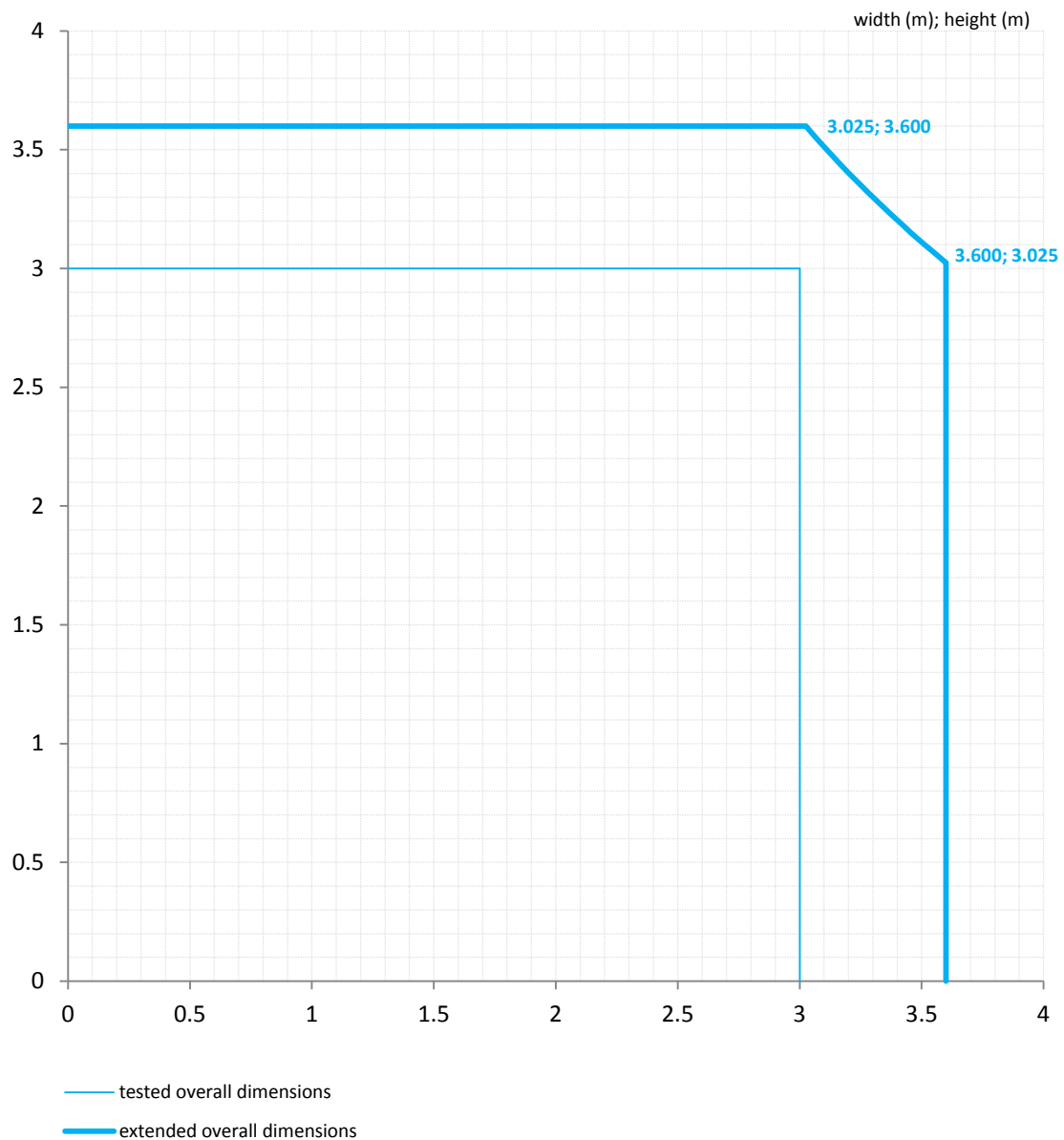

Note:

The maximum overall dimensions of the fire resistant glazed partition are represented by the thickest lines. A wider construction achieved by replicating the extended fire resistant glazed element is allowed.